



Thermal Insulation



Acoustic Insulation



Fire Resistant



Environment Friendly





4 in1 insulation solutions
which deliver superior thermal, fire,
acoustic and sustainable performance..

Contents

■ Company Profile	2
■ Quality Management	3
■ Product Description	4
■ Products Performance	5
■ Saudi Rockwool Product Range	7
● SRW Rockwool Board / Panel	8
● SRW Rockwool Blanket / Felt	9
● SRW Rockwool Batt	10
● SRW Mattress / Wiremesh Blanket	11
■ Application Types	
■ Buildings	
● Cavity Wall System	12
● Ventilated Façade / Stone Cladding	13
● Curtain Wall	14
● ETICS / EIFS	15
● Partition Wall / Dry Wall	16
● Wall Penetration / Firestop	17
● Linear gap Sealing System	18
● Soffit	19
● Concrete Roof	20
● Steel Structure / Built-up Roof System	21
● Sandwich Panels	22
● Fire Door	23
● Ceiling Tiles	24
● Insulated Red Bricks / Blocks	25
■ Industrial	
● Tank & Equipment Insulation	26
● Pipe Insulation (Less than 24" Pipe diameter)	27
● Pipe Insulation (Above 24" Pipe diameter)	28
■ Approvals & Reference Projects	29
■ Acoustic Calculations (STC)	31
■ Thermo-Physical Properties of Building Materials	34



Company Profile

Saudi Rockwool Factory (SRWF) is a subsidiary of Zamil Industrial Investment Company.

Since 1992, we are engaged in manufacturing of high Quality Rockwool insulation products catering the needs of building (Residential & Commercial) & industrial insulation market in the GCC region.

Our first manufacturing plant was established in 1992 with the facility of producing Gray Rockwool products and later Yellow Rockwool products were introduced by SRWF to cope with the latest technology of Cupola.

Currently SRWF has two manufacturing facilities in KSA (Central region) with the combined production capacity of 65,000 tons per annum. This makes us the Largest Manufacturer of Rockwool in the GCC region. SRWF has expertise in producing wide range of Rockwool insulation products like Panel/Slabs, blankets, Mattress with wire mesh, Pipe sections and loose wool.



SRWF Rockwool insulation products helps construction sector fulfill their LEED, Sustainability requirement as well achieving energy efficiency in the buildings and industrial operations.

SRWF has a wide sales network spread across the GCC through strong Dealer networks as well as dedicated SRWF offices in Riyadh, Dammam, Jeddah, Dubai & Qatar to serve the demand of Rockwool insulation of their respective regions.



Quality Management

SRWF strive to provide reliable products, on-time delivery and dependable support to meet customer's highest expectations. We listen to our customer and convince them with our performance and innovation. We supply flawless products and services to ensure our customer's highest satisfaction.

The highly equipped in-house laboratory is utilized to perform most of raw material and product testing. SRWF products are tested at regular intervals by local and International third party laboratories.

SRWF products are tested & certified for Thermal, Acoustic & Fire properties and possess various certificates like UL, CE, FM Approval, UL Green guard, DCL, SASO, Warrington (Euro Fire Classification Class A1), IMO and many more..

SRWF maintains ISO 9001 Quality system certification since 1998.

SRWF products are approved for use in buildings by Saudi Civil Defense, Dubai Civil Defense, Qatar Civil Defense and Bahrain Civil Defense.

Being an insulation manufacturer, we are committed to provide Eco-friendly insulation material to achieve Sustainability requirement of a building and help to protect & preserve the environment for our future generations.

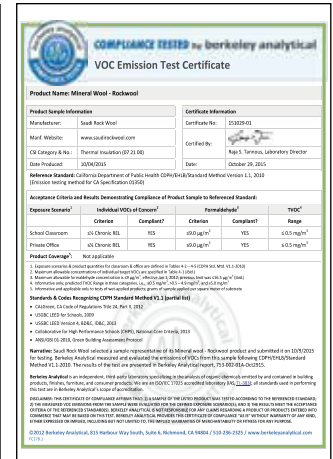
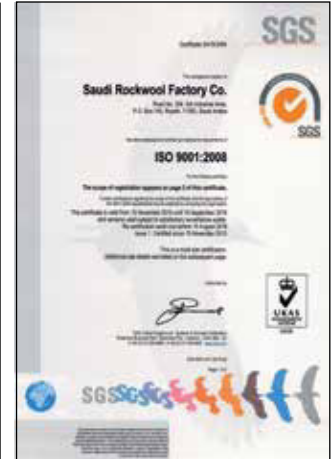

Description

SRW Rockwool Insulation Products are manufactured melting natural rocks (Basalt) at 1600°C, making it naturally durable and stable. Rockwool fibers are Natural inorganic mineral fibers which exhibits life Cycle similar to a rock.



The unique physical structure of SRWF Rockwool keeps its shape and toughness, and it is not affected by changes in temperature or humidity.

Rockwool is a highly efficient insulation and used in most of the known application requiring thermal, acoustic and fire insulation, thanks to its very low thermal conductivity, very high melting temperature and its open cell structure.

SRWF offer a complete range of product for Building Insulation applications to enhance the Energy efficiency of the building.

SRWF Rockwool insulation are used under extreme conditions of temperature and it retains its insulation properties in both very low and very high (up to 750°C) temperature.

Its ability to withstand at elevated temperature makes it choice of insulation in industrial applications, like high temperature steam pipe lines, Turbine, furnace, Boilers, process equipment and pipe lines.

Features & Benefits

- Reduces Energy Consumption
- Reduces Operating Cost
- Increases System Efficiency
- Excellent acoustical properties
- Non Combustible
- Chemically inert
- Water repellent
- Easy to handle and Install
- Durable and sustainable

Compliance

Standard	Description
ASTM C553	Mineral Fiber Blanket Thermal Insulation for Commercial and Industrial Applications
ASTM C665	Mineral-Fiber Blanket Thermal Insulation for Light Frame Construction and Manufactured Housing
ASTM C 612	Mineral Fiber Block and Board Thermal Insulation
ASTM C 592	Standard Specification for Mineral fiber Blanket Insulation and Blanket-Type Pipe Insulation (Metal-Mesh Covered) (Industrial Type)
BS-EN 13162	Thermal insulation products for buildings-Factory made mineral wool (MW) products Specification
ASTM C1104/C-1104M-00	Water Vapor sorption
ASTM E 96A	Water Vapor Permeability
UL 723 / ASTM E 84	Surface Burning Characteristics
BS EN 13501	Fire classification of construction products and building elements. Classification using test data from reaction to fire tests
ASTM E 136	Standard Test Method for behavior of material in vertical tube furnace @ 750 °C
BS 476-4	Fire tests on building materials and structures. Non-combustibility test for materials
BS 476-6	Fire tests on building materials and structures. Method of test for fire propagation for products
BS 476-7	Fire tests on building materials and structures. Method of test to determine the classification of the surface spread of flame of products
ASTM C 423	Standard Test Method for Sound Absorption and Sound Absorption Coefficients by the Reverberation Room Method

Performance

Thermal insulation and energy saving

Power / energy conservation is one of our civilization aspects for its positive role in conserving the environment and the national economy. Scientific research and studies proved that use of thermal insulation in buildings dramatically reduce the heat transfer through the walls and the roofs.

Today with the raise of energy and living costs, the most practical and cost effective way to make a house more energy efficient is by keeping it cool in summer and warm in winter and save money by lowering your electricity bills by insulating your homes.

Based on the above, rules and regulation were adopted in making thermal insulation in private or public buildings as mandatory. The thermal resistance of walls and ceiling are specified to suit the geographical region of most countries.

Professional studies proved that the thermal insulation cost in a building will not exceed %5-3 of the building cost. This amount however, will be paid back in 5-4 years as a result of the saving in the electricity bill.

Thermal conductivity of Saudi Rock wool

Mean Temp °C	K- Value W/ mk Density kg/m ³						
	35	40	50	70	100	120	140
-4	0.030	0.030	0.029	0.029	0.028	0.027	0.028
10	0.034	0.034	0.033	0.032	0.032	0.031	0.031
24	0.038	0.037	0.036	0.034	0.033	0.033	0.034
35	0.040	0.039	0.037	0.036	0.036	0.035	0.034
50	0.043	0.042	0.039	0.038	0.037	0.036	0.036
100	0.051	0.050	0.049	0.047	0.044	0.043	0.042
150	-	0.061	0.057	0.055	0.052	0.051	0.048
200	0.083	0.079	0.063	0.060	0.060	0.061	0.060
250	0.120	0.110	0.085	0.073	0.068	0.066	0.065
300	0.132	0.120	0.095	0.090	0.080	0.071	0.070
350	-	-	0.120	0.106	0.097	0.094	0.091
400	-	-	-	0.122	0.112	0.108	0.102

Acoustic insulation

The unique structure of the Rockwool makes it an ideal product as a sound absorber or acoustic insulation, with high sound absorption coefficient over a wide frequency range. The acoustical insulation can be made by installing Saudi Rockwool in wall partitions which provide significant improvement in their Sound Transmission Class (STC). High STC can be achieved by using Rockwool with different construction systems (Gypsum board, Cement boards, concrete blocks, etc).

Due to its open cell structure, Saudi rock wool has superior sound absorption properties. (NRC>0.95 For 2" Thick)

Saudi Rockwool used to decrease the reverberation time Sound Level dB of rooms (Class rooms / Studios / Theatre /



Conference halls / Airport terminals) providing comfort and sound intelligibility to both sound source & receiver.

Sound Absorption of Saudi Rockwool (NRC):

Thickness mm	Density Kg/m ³	125 Hz	250 Hz	500 Hz	1000 Hz	2000 Hz	4000 Hz	NRC
15	100	0.05	0.1	0.33	0.72	0.95	0.91	0.55
25	70	0.14	0.25	0.65	0.98	1.01	1.01	0.75
25	100	0.1	0.4	0.8	0.95	0.94	0.9	0.80
25	120	0.08	0.45	0.82	1.03	1.02	1.04	0.85
30	70	0.1	0.4	0.87	0.97	0.9	0.9	0.80
30	100	0.11	0.41	0.94	1.01	1.02	1.01	0.85
30	120	0.18	0.52	0.94	1.04	1.02	1.03	0.90
50	50	0.28	0.72	1.01	1.02	0.98	0.98	0.95
50	70	0.28	0.72	1.09	1.09	1.07	1.07	1.00
50	100	0.33	0.86	1.1	1.09	1.05	0.98	1.00
75	50	0.52	0.96	1.18	1.07	1.05	1.05	1.00
75	120	0.78	0.96	1.04	1.05	1.01	1.02	1.00



Non-Combustibility

SRWF insulation products are classified with Euroclass fire classification "A1" and are Non-combustible as per ASTM E 136. BS EN ISO 1182 & BS EN ISO 1716



Surface Burning Characteristics

When tested in accordance with UL 723/ASTM E 84, "0" Spread of Flame Index

"0" Smoke developed Index.

Which makes it suitable of inside the building insulation application.

Performance

Moisture Absorption:

Less than %0.2 by volume when tested in accordance with ASTM C 1104, ASTM C 209 and EN 1609 & EN 12087. SRWF Rockwool insulations shows no sign of absorbing water by capillary attraction.



Compatible with Building materials

Saudi Rockwool is mainly consists of inorganic compounds such as silica, aluminum, calcium & ferrous, which are found in most of the construction materials (like cement, gypsum, blocks) thus it is more compatible with the building materials..

Light weight, easy to handle and install

Saudi Rockwool is produced with various densities ranging from 30 up to 200kg/m³, according to the required application, therefore the maximum density of Rockwool is equivalent to %15-10 of construction materials densities, and consequently Rockwool will cause no significant load to the building structure . Rockwool is highly flexible material and easy to install with required shape by using a simple cutter or carpenter saw.



Non Toxic

Saudi Rockwool products are certified by **UL GREENGUARD** for low volatile organic compounds. **GREENGUARD Gold** Certified products can be used to earn valuable credits for **LEED certification**. GREENGUARD products are broadly recognized and accepted by sustainable building programs and building codes around the world.

PH Neutrality

SRWF Rockwool insulation is chemically inert and compatible with all types Building material equipments and fittings. A typical extract of Rockwool insulation is natural or slightly alkaline with pH 7 to 9.

Biological

SRWF insulation Product are naturally inert & rot proof material that does not encourage or support the growth of fungi, moulds or bacteria or offer sustenance to insects, when tested as per ASTM C 1338.

Corrosion Resistant

The presence of sodium and silicate ions in the rockwool insulation has found to be inhibit to the external stress corrosion cracking caused by chloride & fluoride ions.

The Concentration of these ions was measured according to the test method of ASTM C 871, it was found that the leachable ions are within the acceptable safe zone as per ASTM C 795. Thus Saudi Rockwool do not cause or initiate or promote any kind of corrosion.



Sustainable & Environmental Friendly

Saudi Rockwool insulations are made from Natural Rock (Basalt), which has “**Zero Ozone Depletion Potential**” and “**Zero Global Warming Potential**”.



Saudi Rockwool Product types:

Saudi Rockwool products are produced by melting the pure basalt rock with the latest Technology of Cupola furnace and this will yield yellow wool products.

Panels



Blanket / Batt



Mattress



Pipe Section



Loose wool



Facing types

- Aluminium foil (FSK/FRK/O-Class/Perforated)
- BFG(Black/White)
- WOBFG
- Kraft Paper
- Bitumen Paper
- GI / SS Wire Mesh
- Metallized Alumium foil
- None

Application:

Commercial



Residential



Industrial



Pipe



SRW Rockwool Board /Panel

Saudi Rockwool panel are manufactured in accordance to ASTM C 612 as both rigid and semi rigid to suit wide range of compressive strength requirements as well suitable for operating temperature range up to 750°C. The Rockwool panels are suitable for thermal, acoustic & fire resistance requirement.

Standard Dimensions

Length (mm)	Width (mm)
1200	600

* Other dimensions are available upon special request.

Product Range

Density (Kg/m ³)	Thermal Conductivity		Thickness (mm)	Thermal Resistance Per Inch (m ² k/w)
	(W/m.K)	Btu in / (h ft ² °F)		
35	0.038	0.26	200-25	0.67
40	0.037	0.26	220-25	0.69
50	0.036	0.25	220-25	0.71
60	0.035	0.24	220-25	0.73
70	0.034	0.24	220-25	0.75
80	0.034	0.24	200-25	0.75
90	0.034	0.24	200-25	0.75
100	0.033	0.23	200-25	0.77
110	0.033	0.23	180-25	0.77
120	0.033	0.23	160-25	0.77
130	0.033	0.23	150-25	0.77
140	0.034	0.24	140-25	0.75
150	0.034	0.24	130-25	0.75
160	0.034	0.24	120-25	0.75
170	0.035	0.24	110-25	0.73
180	0.035	0.24	110-25	0.73
190	0.035	0.24	100-25	0.73
200	0.035	0.24	100-25	0.73

Facing types

Aluminium foil (FSK/FRK/O-Class/Perforated)
 BFG(Black/White)
 WOBF
 Kraft Paper
 Bitumen Paper
 Metallized Aluminium foil
 None



Application

Buildings

- 1) External Facade
- 2) Curtain wall
- 3) Cavity Wall
- 4) Roof (Overdeck / Underdeck)
- 5) Floor Insulation (Acoustic / Thermal)
- 6) Kitchen Exhaust Duct
- 7) Fire Barrier / Joint Filler / Fire Wall Penetration
- 8) Acoustic Insulation of Mechanical Rooms / Equipment's.
- 9) Other Thermal, Fire & Acoustic Applications.

Industrial

- 1) Tanks
- 2) Equipment
- 3) Flange Boxes
- 4) Fire Proofing of Steel Structure / Cable trays
- 5) Acoustic Insulation of equipment's at high temperature
- 6) Chimneys



SRW Rockwool Blanket /Felt

Saudi Rockwool LD Blanket or felt is manufactured in accordance with ASTM C665- and ASTM C553- standard. These blanket are flexible light in weight faced with Aluminum foil or Kraft paper to act as a vapor barrier.



Standard Dimensions

Length (mm)	Width (mm)
10000 - 5000	1200

* Other dimensions are available upon special request.

Product Range

Density (Kg/m ³)	Thermal Conductivity		Thickness (mm)	Thermal Resistance Per Inch (m ² K/W)
	(W/mK)	Btu in / (h ft ² °F)		
35	0.038	0.26	100-25	0.67
40	0.037	0.26	100-25	0.69
50	0.036	0.25	100-25	0.71
60	0.035	0.24	100-25	0.73
70	0.034	0.24	100-25	0.75



Application

Buildings

- 1) Pre Engineered Buildings
- 2) Built-up Roofs
- 3) Acoustical Insulation of Equipment
- 4) Other Thermal & Acoustic Applications

Facing types

Aluminium foil (FSK/FRK/O-Class/Perforated)

NRC –Noise Reduction Coefficient

The **Noise Reduction Coefficient (NRC)** is a scalar representation of the amount of sound energy absorbed upon striking a particular surface.

NRC of 0 indicates = perfect reflection

NRC of 1 indicates = perfect absorption

Sound Transmission Class (STC) is an integer rating of how well a building partition attenuates airborne **sound**.

Density (Kg/m ³)	Thickness (mm)	NOISE REDUCTION COEFFICIENT						NRC
		Octave Frequencies (Hz)						
		125	250	500	1000	2000	4000	
40	75	0.21	0.92	1.24	1.15	1.07	1.1	1.1
50	50	0.28	0.72	1.01	1.02	0.98	0.98	0.95
	75	0.52	0.96	1.18	1.07	1.05	1.05	1
70	25	0.14	0.25	0.65	0.98	1.01	1.01	0.75
	30	0.1	0.4	0.87	0.97	0.9	0.9	0.8
	50	0.28	0.72	1.09	1.09	1.07	1.07	1



SRW Rockwool Batt

Saudi Rockwool Batt Insulation is manufactured in accordance with ASTM C665-, ASTM C553- and ASTM C612. These Batt are flexible / semi rigid light in weight faced / unfaced Rockwool Insulation



Standard Dimensions

Length (mm)	Width (mm)
1200	1200 - 600

* Other dimensions are available upon special request.

Product Range

Density (Kg/m ³)	Thermal Conductivity		Thickness (mm)	Thermal Resistance Per Inch (m ² k/w)
	(W/m.K)	Btu in / (hft ² °F)		
35	0.038	0.26	200-25	0.67
40	0.037	0.26	220-25	0.69
50	0.036	0.25	220-25	0.71
60	0.035	0.24	220-25	0.73
70	0.034	0.24	220-25	0.75
80	0.034	0.24	200-25	0.75
90	0.034	0.24	200-25	0.75
100	0.033	0.23	200-25	0.77
110	0.033	0.23	180-25	0.77
120	0.033	0.23	160-25	0.77
130	0.033	0.23	150-25	0.77
140	0.034	0.24	140-25	0.75
150	0.034	0.24	130-25	0.75
160	0.034	0.24	120-25	0.75



Facing types

None
Aluminium foil (FSK/FRK/O-Class/Perforated)

Application

Buildings

- 1) Built-up Roofs
- 2) Light Frame Steel Structure roofs / Walls
- 3) Dry Wall Partitions
- 4) Acoustical Insulation of Mechanical Rooms / Equipment's.
- 5) Other Thermal, Fire & Acoustic Applications.

Industrial

- 1) Tanks
- 2) Equipment
- 3) Furnace, Turbine, Blower, Reformers, Boilers
- 4) Fire Proofing of Steel Structure / Cable trays



SRW Mattress / Wiremesh Blanket

Saudi Rockwool Mattress are manufactured in accordance with ASTM C 592, BS 3958 Part3-. Saudi Rockwool mattress backed with hexagonal GI or SS wire mesh (one or both sides) to support Rockwool fibers during and after application.

Saudi Rockwool Mattress are bonded lightly with the help of thermosetting resin. Low resin content with Low VOC content makes it environment friendly and suitable for high temperature applications up to 750C, in industrial application and flexible to apply on flat, uneven surfaces as well pipes with large diameters.

Standard Dimensions

Length (mm)	Width (mm)
4000	1200

* Other dimensions are available upon special request.

Product Range

Density (Kg/m ³)	Thermal Conductivity		Thickness (mm)	Thermal Resistance Per inch (m ² k/w)
	(W/mk)	Btu in / (h ft ² F)		
70	0.034	0.24	120-30	0.75
80	0.033	0.23	120-25	0.77
90	0.033	0.23	120-25	0.77
100	0.033	0.23	120-25	0.77
110	0.033	0.23	120-25	0.77
120	0.033	0.23	100-25	0.77
130	0.033	0.23	100-25	0.77
140	0.034	0.24	100-25	0.75
150	0.034	0.24	100-25	0.75

Facing

- G.I Wire Mesh
- S.S Wire Mesh



Applications

Buildings

- 1) Kitchen Exhaust Duct
- 2) Fire Proofing
- 3) Fire Stop / Fire Barrier
- 4) Acoustical Insulation of Mechanical Rooms / Equipment's.
- 5) Other Thermal, Fire & Acoustic Applications.

Industrial

- 1) Tanks
- 2) Equipment
- 3) Furnace, Turbine, Blower's Reformers, Boilers
- 4) Pipe Lines
- 5) Fire Proofing of Steel Structure / Cable trays
- 6) Acoustic Insulation of equipment's at high temperature

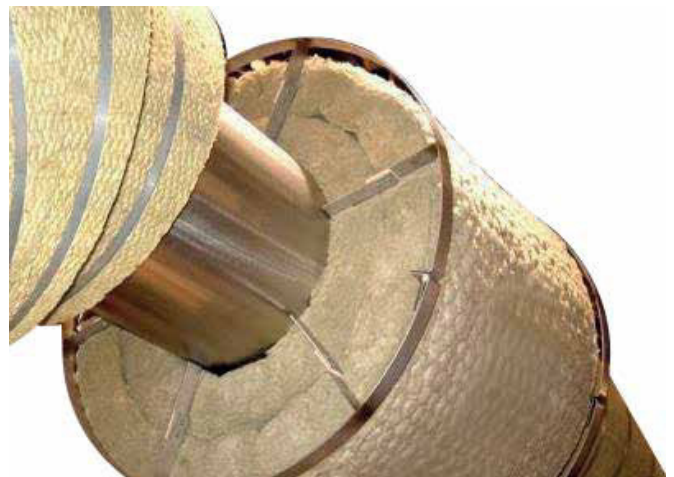

Cavity Wall System

A void/Gap formed by two walls either of the following components i.e. Precast panels, Concrete Block wall and Concrete walls.

SRWF Cavity Panels

Rigid Non combustible Rockwool Board Insulation with excellent thermal and acoustic properties suitable for Cavity Wall insulation.

SRW Cavity Panel are manufactured in conformance to ASTM C 612, BS 3958 Part - 5, and other various international standards as well to BS EN 13162 : 2012 "Specification for factory-made mineral wool products".

SRWF Cavity Panels are available in wide range to serve the purpose of thermal requirement for external wall



Density

128 – 35 Kg/m³

Thickness

200 – 50 mm

Facing

None
Aluminum Foil (FSK/FRK)
BFG



Thermal Properties

			R-Value												U-Value											
Density	Thermal Conductivity		Thickness (mm)									Thickness (inch)			Thickness (mm)						Thickness (inch)					
	(Kg/m ³)	(W/m.K)	(Btu in / (h ft ² °F))	50	60	70	80	100	120	150	2	3	4	5	6	50	60	70	80	100	120	150	2	3	4	5
35	0.038	0.26	1.32	1.58	1.84	2.11	2.63	3.16	3.95	8	11	15	19	23	0.76	0.63	0.54	0.48	0.38	0.32	0.25	0.13	0.09	0.07	0.05	0.04
40	0.037	0.26	1.35	1.62	1.89	2.16	2.70	3.24	4.05	8	12	16	20	24	0.74	0.62	0.53	0.46	0.37	0.31	0.25	0.12	0.08	0.06	0.05	0.04
50	0.036	0.25	1.39	1.67	1.94	2.22	2.78	3.33	4.17	8	12	16	20	24	0.72	0.60	0.51	0.45	0.36	0.30	0.24	0.12	0.08	0.06	0.05	0.04
70	0.034	0.24	1.47	1.76	2.06	2.35	2.94	3.53	4.41	8	13	17	21	25	0.68	0.57	0.49	0.43	0.34	0.28	0.23	0.12	0.08	0.06	0.05	0.04
100	0.033	0.23	1.52	1.82	2.12	2.42	3.03	3.64	4.55	9	13	17	22	26	0.66	0.55	0.47	0.41	0.33	0.28	0.22	0.11	0.08	0.06	0.05	0.04
Units			m ² K/W									(h ft ² °F)/Btu			W/m ² K						Btu/(h ft ² °F)					

Ventilated Façade / Stone Cladding

A ventilated facade is a cladding system with an air cushion or cavity immediately behind which provides with a drainage, ventilation and thermal solution. It is usually an external cladding system mechanically fastened or bonded to a framework behind fixed to the external wall of a new or existing building..



SRW Thermal Board

Rigid Non combustible, water repellent grade Rockwool Rigid Board Insulation for external ventilated facade system. Rockwool insulation is dimensionally stable and best suitable for external envelope system in comparison to organic foam insulation.

SRW Thermal Board are manufactured in conformance to ASTM C 612, BS 3958 Part5-, and other various international standards and comply to the requirement of BS EN 2012 : 13162



Density

160 – 50 Kg/m³

Thickness

200 – 50mm

Facing

- None
- Aluminum Foil (FSK/FRK)
- BFG



Thermal Properties

			R-Value												U-Value											
Density	Thermal Conductivity		Thickness (mm)								Thickness (inch)				Thickness (mm)						Thickness (inch)					
	(Kg/m ³)	(W/m.K)	Btu in / (h ft ² °F)	50	60	70	80	100	120	150	2	3	4	5	6	50	60	70	80	100	120	150	2	3	4	5
50	0.036	0.25	1.39	1.67	1.94	2.22	2.78	3.33	4.17	8	12	16	20	24	0.72	0.60	0.51	0.45	0.36	0.30	0.24	0.12	0.08	0.06	0.05	0.04
70	0.034	0.24	1.47	1.76	2.06	2.35	2.94	3.53	4.41	8	13	17	21	25	0.68	0.57	0.49	0.43	0.34	0.28	0.23	0.12	0.08	0.06	0.05	0.04
130 - 100	0.033	0.23	1.52	1.82	2.12	2.42	3.03	3.64	4.55	9	13	17	22	26	0.66	0.55	0.47	0.41	0.33	0.28	0.22	0.11	0.08	0.06	0.05	0.04
160 - 140	0.034	0.24	1.47	1.76	2.06	2.35	2.94	3.53	4.41	8	13	17	21	25	0.68	0.57	0.49	0.43	0.34	0.28	0.23	0.12	0.08	0.06	0.05	0.04
Units			m ² K/W								(h ft ² °F)/Btu				W/m ² K						Btu/(h ft ² °F)					

Curtain Wall

A curtain wall system is an outer covering of a building in which the outer walls are non-structural, keep the weather out and the occupants in.

SRW Thermal & Fire Board

Rigid / Semi Rigid Non combustible Rockwool Board Insulation with excellent thermal and acoustic properties suitable for Curtain Wall systems.

SRW Thermal & Fire Board are used in combination at curtain wall system, Thermal Board as thermal barrier to prevent heat gain to the building and fire board in the Gap between the slab and the curtain wall.

SRW Thermal Boards & Fire Boards are manufactured in conformance to ASTM C 612, BS 3958 Part 5-, and other various international standards as well comply to the requirement to BS EN 13162 : 2012 "Specification for factory-made mineral wool products". And achieves Euroclass fire classification "A1".

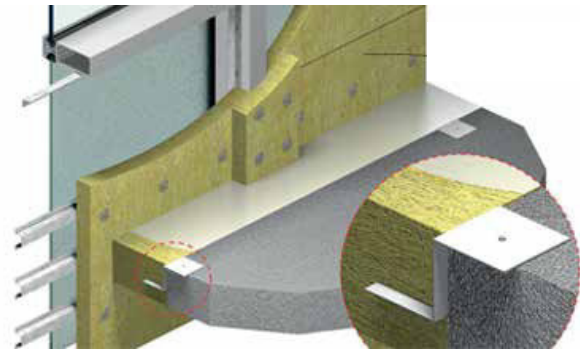

Density

Thermal Board :- 128 - 50 Kg/m³
 Fire Board :- 200 - 64 Kg/m³

Thickness

200 - 50mm

Facing

Aluminium foil (FSK/FRK/O-Class)
 None



Thermal Properties

			R-Value												U-Value											
Density	Thermal Conductivity		Thickness (mm)									Thickness (inch)			Thickness (mm)						Thickness (inch)					
	(Kg/m ³)	(W/m.K)	Btu in / (h ft ² °F)	50	60	70	80	100	120	150	2	3	4	5	6	50	60	70	80	100	120	150	2	3	4	5
50	0.036	0.25	1.39	1.67	1.94	2.22	2.78	3.33	4.17	8	12	16	20	24	0.72	0.60	0.51	0.45	0.36	0.30	0.24	0.12	0.08	0.06	0.05	0.04
70	0.034	0.24	1.47	1.76	2.06	2.35	2.94	3.53	4.41	8	13	17	21	25	0.68	0.57	0.49	0.43	0.34	0.28	0.23	0.12	0.08	0.06	0.05	0.04
128 - 100	0.033	0.23	1.52	1.82	2.12	2.42	3.03	3.64	4.55	9	13	17	22	26	0.66	0.55	0.47	0.41	0.33	0.28	0.22	0.11	0.08	0.06	0.05	0.04
Units			m ² K/W									(h ft ² °F)/Btu			W/m ² K						Btu/(h ft ² °F)					

ETICS / EIFS

Modern, high-quality external thermal insulation composite system (ETICS/EIFS).

SRW Thermal Board

High Density Rigid Non combustible Rock wool Board Insulation with excellent thermal and acoustic properties suitable for ETICS / EIFS systems.

ETICS / EIFS systems create thermal envelope external to the building without any thermal bridges. Most advanced external wall insulation systems prevent building from exposure to weather conditions, resulting in increased building life.

SRW Thermal Boards are manufactured in conformance to ASTM C 612, BS 3958 Part - 5, and other various international standards as well as comply to the requirement to BS EN 13162 : 2012 "Specification for factory - made mineral wool products".

Rockwool High Density Thermal Board has high compressive strength & high impact sound absorption capacity.

Density

Min. 200 - 100kg/m³

Thickness

150 - 50 mm

Facing

None

Thermal Properties



			R-Value												U-Value											
Density	Thermal Conductivity		Thickness (mm)							Thickness (inch)					Thickness (mm)						Thickness (inch)					
	(kg/m ³)	(W/m.K)	Btu.in / (h.ft ² .°F)	50	60	70	80	100	120	150	2	3	4	5	6	50	60	70	80	100	120	150	2	3	4	5
130 - 100	0.033	0.23	1.52	1.82	2.12	2.42	3.03	3.64	4.55	9	13	17	22	26	0.66	0.55	0.47	0.41	0.33	0.28	0.22	0.11	0.08	0.06	0.05	0.04
160 - 140	0.034	0.24	1.47	1.76	2.06	2.35	2.94	3.53	4.41	8	13	17	21	25	0.68	0.57	0.49	0.43	0.34	0.28	0.23	0.12	0.08	0.06	0.05	0.04
200 - 170	0.035	0.24	1.43	1.71	2.00	2.29	2.86	3.43	4.29	8	12	16	21	25	0.70	0.58	0.50	0.44	0.35	0.29	0.23	0.12	0.08	0.06	0.05	0.04
Units			m ² K/W							(h.ft ² .°F)/Btu					W/m ² K						Btu/(h.ft ² .°F)					

Partition Wall / Dry Wall System

Partition wall system is a non load bearing separation wall which separates two interior spaces / rooms.

SRWF Acoustic Batt/Panel

Flexible / Semi Rigid / Rigid Non combustible Rockwool Insulation with excellent acoustic and Fire properties suitable for Partition Wall insulation.

SRW Acoustic Batt / Panel are manufactured in conformance to ASTM C 665, ASTM C 553 or ASTM C 612 and other various international standards.

SRWF Acoustic Batt/Panel are suitable for Acoustic Insulation for Home Theatres, Conference Hall and other Acoustic Application.



Density

100 – 35Kg/m³

Thickness

150 – 50mm

Facing

None
BFG
WOBFG



NRC –Noise Reduction Coefficient

The **Noise Reduction Coefficient (NRC)** is a scalar representation of the amount of sound energy absorbed upon striking a particular surface.

NRC of 0 indicates = perfect reflection

NRC of 1 indicates = perfect absorption

Sound Transmission Class (STC) is an integer rating of how well a building partition attenuates airborne **sound**.

NOISE REDUCTION COEFFICIENT								
Density	Thickness	Octave Frequencies (Hz)						NRC
(Kg/m ³)	(mm)	125	250	500	1000	2000	4000	
40	75	0.21	0.92	1.24	1.15	1.07	1.1	1.1
50	50	0.28	0.72	1.01	1.02	0.98	0.98	0.95
	75	0.52	0.96	1.18	1.07	1.05	1.05	1
70	25	0.14	0.25	0.65	0.98	1.01	1.01	0.75
	30	0.1	0.4	0.87	0.97	0.9	0.9	0.8
	50	0.28	0.72	1.09	1.09	1.07	1.07	1
100	15	0.05	0.1	0.33	0.72	0.95	0.91	0.55
	25	0.1	0.4	0.8	0.95	0.94	0.9	0.8
	30	0.11	0.41	0.94	1.01	1.02	1.01	0.85
	50	0.33	0.86	1.1	1.09	1.05	0.98	1

Thermal Properties

			R-Value						U-Value																	
Density	Thermal Conductivity		Thickness (mm)						Thickness (inch)						Thickness (mm)						Thickness (inch)					
	(Kg/m ³)	(W/m.K)	Btu in / (h ft ² F)	50	60	70	80	100	120	150	2	3	4	5	6	50	60	70	80	100	120	150	2	3	4	5
35	0.038	0.26	1.32	1.58	1.84	2.11	2.63	3.16	3.95	8	11	15	19	23	0.76	0.63	0.54	0.48	0.38	0.32	0.25	0.13	0.09	0.07	0.05	0.04
40	0.037	0.26	1.35	1.62	1.89	2.16	2.70	3.24	4.05	8	12	16	20	24	0.74	0.62	0.53	0.46	0.37	0.31	0.25	0.12	0.08	0.06	0.05	0.04
50	0.036	0.25	1.39	1.67	1.94	2.22	2.78	3.33	4.17	8	12	16	20	24	0.72	0.60	0.51	0.45	0.36	0.30	0.24	0.12	0.08	0.06	0.05	0.04
70	0.034	0.24	1.47	1.76	2.06	2.35	2.94	3.53	4.41	8	13	17	21	25	0.68	0.57	0.49	0.43	0.34	0.28	0.23	0.12	0.08	0.06	0.05	0.04
100	0.033	0.23	1.52	1.82	2.12	2.42	3.03	3.64	4.55	9	13	17	22	26	0.66	0.55	0.47	0.41	0.33	0.28	0.22	0.11	0.08	0.06	0.05	0.04
Units			m ² K/W						(h ft ² F)/Btu						W/m ² K						Btu/(h ft ² F)					

Wall Penetration / Firestop

Openings through the walls for Pipes, fittings, cable trays to pass through are called wall penetration joints and fire propagation through these joints is of major concern.

SRWF Fire Board

Non combustible, water repellent grade Rockwool board Insulation. The product is suitable to achieve up to 4 hrs of fire rating when installed with in the cavity formed between wall and the components passing through the wall respective to thickness of the wall. The product is suitable to be used with various type of fire rated sealants.

SRW Thermal Board are manufactured in conformance to ASTM C 612, BS 3958 Part5-, and other various international standards and comply to the requirement of BS EN 2012 : 13162.

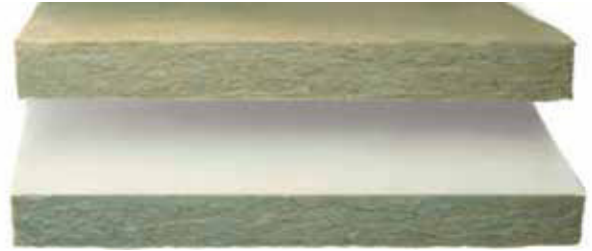

Density

200 - 64 Kg/m³

Thickness

150- 50 mm

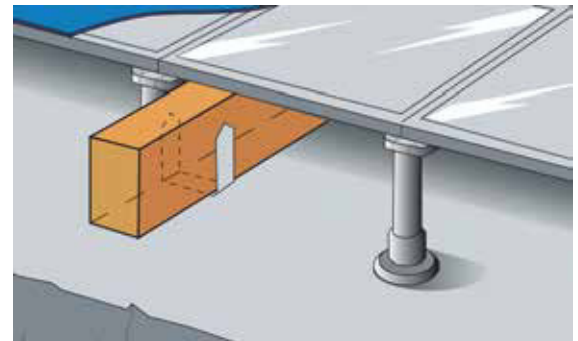

Facing

None
Intumescent Fire Proof Coating

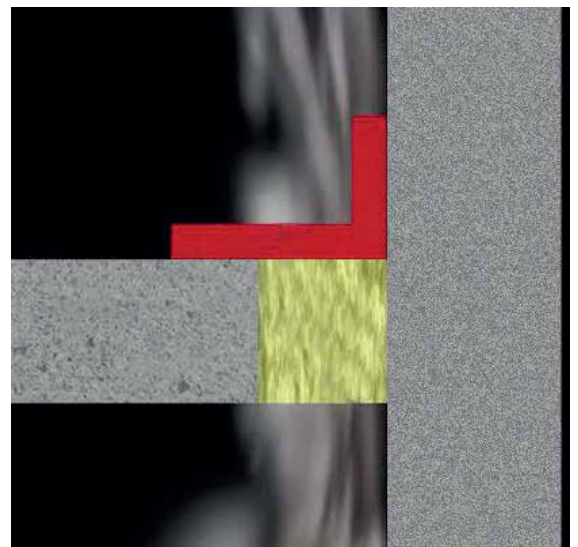

Fire Rating System Integrity

Thickness (mm)	Filled with Rockwool
50	1 hr
100	2 hr
150	3 hr
200	4 hr

*Density :- 100 Kg/m³ and also depend on the wall system

Linear Gap Sealing System

A gap formed between the top of the wall and the bottom of the roof/ceiling slabs are named as linear Gap.

SRW Rockwool Gap filler Board

SRW fire board products are recommended to prevent the passage fire & smoke to transfer from one compartment to other through the linear Gap.

SRW Gap filler board are Semi Rigid / Rigid Non - combustible Rockwool Insulation with compressibility suitable for application with in Linear Gap, and manufactured in conformance to ASTM C 612 and other international standards.

SRWF Rockwool Panel / Board has the ability to be compressed and filed within the gap to prevent transfer of Fire and smoke through the gap. It also acts as a barrier for sound.

Density

160 - 64 Kg/m³

Thickness

100 - 25 mm

Facing

None

Fire Rating System Integrity

Thickness (mm)	Uncoated Rockwool
50	1 hr
100	2 hr
150	3 hr
200	4 hr

*Thickness on insulation shall be considered in the direction of Fire

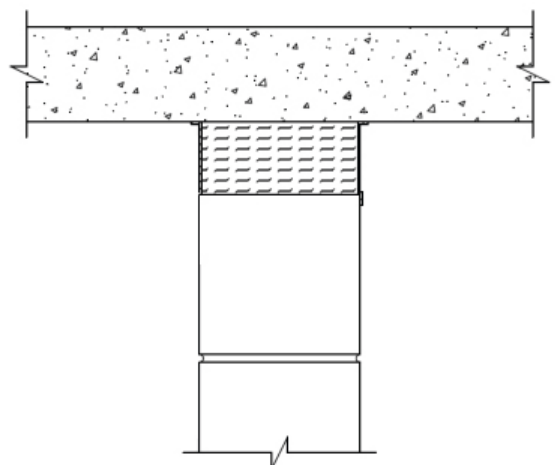

Soffit

Underside of an architectural structure such as an arch, a balcony, or overhanging eaves

SRW Acoustic Fire Board

SRW Rock Soffit Board a Rigid Non combustible Rockwool Board Insulation for Concrete Soffit & similar insulation of Buildings.

SRW Rock Soffit Board are manufactured in conformance with ASTM C 612 , BS EN 3958 Part - 5 and other various international standards.

Density

Min.128 - 70 Kg/m³

Thickness

150 – 50 mm

Facing

- None
- BFG (Black/White)
- WOBFG
- Aluminum Foil (FSK/FRK)



NRC –Noise Reduction Coefficient

The **Noise Reduction Coefficient (NRC)** is a scalar representation of the amount of **sound** energy absorbed upon striking a particular surface.

- NRC** of 0 indicates = perfect reflection
- NRC** of 1 indicates = perfect absorption

Sound Transmission Class (STC) is an integer rating of how well a building partition attenuates airborne **sound**.

Density (Kg/m ³)	Thickness (mm)	NOISE REDUCTION COEFFICIENT						NRC
		Octave Frequencies (Hz)						
		125	250	500	1000	2000	4000	
70	25	0.14	0.25	0.65	0.98	1.01	1.01	0.75
	30	0.1	0.4	0.87	0.97	0.9	0.9	0.8
	50	0.28	0.72	1.09	1.09	1.07	1.07	1
	15	0.05	0.1	0.33	0.72	0.95	0.91	0.55
100	25	0.1	0.4	0.8	0.95	0.94	0.9	0.8
	30	0.11	0.41	0.94	1.01	1.02	1.01	0.85
	50	0.33	0.86	1.1	1.09	1.05	0.98	1

Thermal Properties

Density (Kg/m ³)	Thermal Conductivity (W/m.K) Btu in / (h ft ² °F)		R-Value												U-Value											
			Thickness (mm)								Thickness (inch)				Thickness (mm)						Thickness (inch)					
			50	60	70	80	100	120	150	2	3	4	5	6	50	60	70	80	100	120	150	2	3	4	5	6
70	0.034	0.24	1.47	1.76	2.06	2.35	2.94	3.53	4.41	8	13	17	21	25	0.68	0.57	0.49	0.43	0.34	0.28	0.23	0.12	0.08	0.06	0.05	0.04
128 - 100	0.033	0.23	1.52	1.82	2.12	2.42	3.03	3.64	4.55	9	13	17	22	26	0.66	0.55	0.47	0.41	0.33	0.28	0.22	0.11	0.08	0.06	0.05	0.04
Units			m ² K/W								(h ft ² °F)/Btu				W/m ² K						Btu/(h ft ² °F)					

Concrete roof

A roof is part of a building envelope. It is the covering on the uppermost part of a building or shelter which provides protection from weather, notably rain or snow, but also heat, wind and sunlight.



SRW Rockwool HD Roof Board

SRW HD roofing board are suitable to insulate the roof, the high density roof board are designed to have high compressive strength which complies the requirement of ASTM C 726.

SRW HD Roof Boards are manufactured in accordance with ASTM C 612, BS 3958 Part - 5 and other international standards and comply to the requirement of BS EN 12125 : 13162.

Density

Min. 200 – 120 Kg/m³

Thickness

150-50 mm

Facing

None
Bitumen
PE

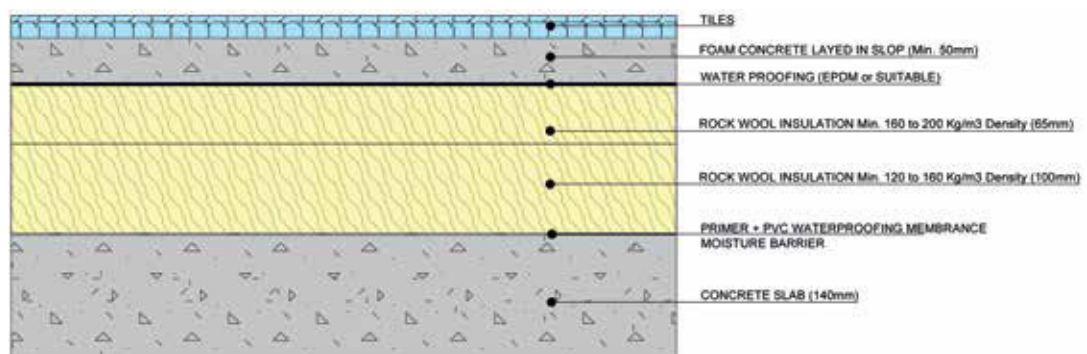

Thermal Properties

			R-Value												U-Value											
Density (Kg/m ³)	Thermal Conductivity		Thickness (mm)						Thickness (inch)						Thickness (mm)						Thickness (inch)					
	[W/m.K]	Btu.in / (h.ft ² .°F)	50	60	70	80	100	120	150	2	3	4	5	6	50	60	70	80	100	120	150	2	3	4	5	6
130 - 120	0.033	0.23	1.52	1.82	2.12	2.42	3.03	3.64	4.55	9	13	17	22	26	0.66	0.55	0.47	0.41	0.33	0.28	0.22	0.11	0.08	0.06	0.05	0.04
160 - 140	0.034	0.24	1.47	1.76	2.06	2.35	2.94	3.53	4.55	8	13	17	21	25	0.68	0.57	0.49	0.43	0.34	0.28	0.23	0.12	0.08	0.06	0.05	0.04
200 - 170	0.035	0.24	1.43	1.71	2.00	2.29	2.86	3.43	4.29	8	12	16	21	25	0.70	0.58	0.50	0.44	0.35	0.29	0.23	0.12	0.08	0.06	0.05	0.04
Units			m ² K/W						(h.ft ² °F)/Btu						W/m ² K						Btu/(h.ft ² °F)					

Steel Structure / Built-Up Roof system

A roofing system constructed with the help of steel structural framing member like trusses, purlins & metal sheets. They are used in almost every industrial and airport terminal building and can also be used in residential and educational buildings. They make for an extremely light, strong, economical, and waterproof roof. Commonly used metals are mild steel, aluminum, and stainless steel. Steel roofing sheets need to be protected from corrosion, and are usually galvanized or coated with other protective layers. The sheets are quite thin, as much as 0.5mm in the case of steel, and 1mm in aluminum. They therefore require insulation and other layers to be incorporated.



SRW Flexible Blanket / Batt / Panels

Flexible / Semi Rigid / Rigid Non combustible Rockwool Insulation with excellent acoustic & Fire properties suitable for Roofing systems single skin / Double Skin, Standing seam. The products are available in wide range of thickness and density with type of facings or without facing. Depends on type of applications products are customized to provide compressibility or rigidity as desired.

It's Stable thermal performance irrespective of climate driven mean temperature, thermal performance remain stable and unmatched compare to other foam insulations..

SRW Rockwool Blankets / Batt Insulation are manufactured in conformance to ASTM C 665, ASTM C 553 or ASTM C 612 and other various international standards.

NRC –Noise Reduction Coefficient

The **Noise Reduction Coefficient (NRC)** is a scalar representation of the amount of **sound** energy absorbed upon striking a particular surface.

NRC of 0 indicates = perfect reflection

NRC of 1 indicates = perfect absorption

Sound Transmission Class (STC) is an integer rating of how well a building partition attenuates airborne **sound**.

Density (Kg/m ³)	Thickness (mm)	NOISE REDUCTION COEFFICIENT						NRC
		Octave Frequencies (Hz)						
		125	250	500	1000	2000	4000	
40	75	0.21	0.92	1.24	1.15	1.07	1.1	1.1
	50	0.28	0.72	1.01	1.02	0.98	0.98	0.95
70	75	0.52	0.96	1.18	1.07	1.05	1.05	1
	25	0.14	0.25	0.65	0.98	1.01	1.01	0.75
	30	0.1	0.4	0.87	0.97	0.9	0.9	0.8
100	50	0.28	0.72	1.09	1.09	1.07	1.07	1
	15	0.05	0.1	0.33	0.72	0.95	0.91	0.55
	25	0.1	0.4	0.8	0.95	0.94	0.9	0.8
	30	0.11	0.41	0.94	1.01	1.02	1.01	0.85
	50	0.33	0.86	1.1	1.09	1.05	0.98	1

Density

160 – 30 Kg/m³

Thickness

200 – 50 mm

Facing

Aluminium Foil / None

Thermal Properties

Density (kg/m ³)	Thermal Conductivity (W/m.K) Btu in / (h ft ² °F)	R-Value										U-Value														
		Thickness (mm)								Thickness (inch)		Thickness (mm)						Thickness (inch)								
		50	60	70	80	100	120	150	2	3	4	5	6	50	60	70	80	100	120	150	2	3	4	5	6	
40	0.037	0.26	1.35	1.62	1.89	2.16	2.70	3.24	4.05	8	12	16	20	24	0.74	0.62	0.53	0.46	0.37	0.31	0.25	0.12	0.08	0.06	0.05	0.04
50	0.036	0.25	1.39	1.67	1.94	2.22	2.78	3.33	4.17	8	12	16	20	24	0.72	0.60	0.51	0.45	0.36	0.30	0.24	0.12	0.08	0.06	0.05	0.04
70	0.034	0.24	1.47	1.76	2.06	2.35	2.94	3.53	4.41	8	13	17	21	25	0.68	0.57	0.49	0.43	0.34	0.28	0.23	0.12	0.08	0.06	0.05	0.04
130-100	0.033	0.23	1.52	1.82	2.12	2.42	3.03	3.64	4.55	9	13	17	22	26	0.66	0.55	0.47	0.41	0.33	0.28	0.22	0.11	0.08	0.06	0.05	0.04
160-140	0.034	0.24	1.47	1.76	2.06	2.35	2.94	3.53	4.41	8	13	17	21	25	0.68	0.57	0.49	0.43	0.34	0.28	0.23	0.12	0.08	0.06	0.05	0.04
Units		m ² K/W								(h ft ² °F)/Btu		W/mK						°Btu/(h ft ² °F)								

Sandwich Panels

A **sandwich panel** is a prefabricated structure made of three layers, low density core inserted in between two relatively thin skin layers. This **sandwich** setup allows to achieve excellent mechanical performance at minimal weight. Sandwich panels are used in applications where high structural rigidity and low weight are required.

sandwich panels are used in facades, roofs, partition walls and ceilings. The most typical applications include industrial and commercial buildings, sports halls, warehouses and power plants. The panels are also suitable for food industry construction

Sandwich panels with Rockwool Insulation core are a combination of thermal as well fire resistance which also perform as acoustic barrier. the acoustic performance of the sandwich panel enhanced with perforated skin sheet.



SRW Sandwich Board

Rockwool Panels for Sandwich Panels applications are manufactured with utmost care to maintain the fiber orientations, while applying between the two skins sheets the orientation of the fiber shall remain perpendicular to give max. possible compressive strength.

SRW Rockwool Sandwich Board are manufactured in conformance to ASTM C 612, BS 3958 Part 5-, and other various international standards as well comply to the requirement to BS EN 13162 : 2012 "Specification for factory-made mineral wool products".

Thickness

200 - 30 mm

Density

200 - 100 Kg/m³

Thermal Properties

Facing

None

			R-Value								U-Value															
Density (kg/m ³)	Thermal Conductivity		Thickness (mm)						Thickness (inch)		Thickness (mm)						Thickness (inch)									
	(W/m.K)	Btu in / (h ft ² °F)	50	60	70	80	100	120	150	2	3	4	5	6	50	60	70	80	100	120	150	2	3	4	5	6
130 - 100	0.033	0.23	1.52	1.82	2.12	2.42	3.03	3.64	4.55	9	13	17	22	26	0.66	0.55	0.47	0.41	0.33	0.28	0.22	0.11	0.08	0.06	0.05	0.04
160 - 140	0.034	0.24	1.47	1.76	2.06	2.35	2.94	3.53	4.41	8	13	17	21	25	0.68	0.57	0.49	0.43	0.34	0.28	0.23	0.12	0.08	0.06	0.05	0.04
200 - 170	0.035	0.24	1.43	1.71	2.00	2.29	2.86	3.43	4.29	8	12	16	21	25	0.70	0.58	0.50	0.44	0.35	0.29	0.23	0.12	0.08	0.06	0.05	0.04
Units			m ² K/W						(h ft ² °F)/ Btu		W/m ² K						Btu/(h ft ² °F)									

FIRE DOOR

A fire door is a door with a fire-resistance rating (sometimes referred to as a fire protection rating for closures) used as part of a passive fire protection system to reduce the spread of fire and smoke. Both the door leaf (the swinging panel of the door) and the door frame are required to meet the guidelines of the Fire Rated testing methods to achieve the rated fire rating.

Rockwool plays a major role creating non-combustible on non-conductive core between outer and inner skins of the door leaf and the door frame. Rockwool high operating as well high melting temperature makes it the choice of OEM's engaged in the manufacturing of Fire rated doors.



SRWF Fire Board

High density Rockwool insulation fire boards are non-combustible to ASTM E 136, and as per BS En 1182, has Euroclass fire classification "A1". Class "O" fire classification in accordance with BS 476 Part7-

SRW Rockwool Sandwich Board are manufactured in conformance to ASTM C 612, BS 3958 Part 5-, and other various international standards as well comply to the requirement of BS EN 13162 : 2012 "Specification for factory-made mineral wool products".

Density

200 - 64 Kg/m³

Thickness

150 - 40 mm

Facing

None



Hourly Ratings

Steel fire doors are "rated" by time (in minutes or hours) that a door can withstand exposure to fire test conditions. Basically Fire door assemblies have 5 ratings:

20 minute

45 minute

1 hour

2/1-1 hour

3 hour

The rating of a fire door assembly is based on the lowest rated component.

Ceiling Tiles

Ceiling tiles are structure hanging just below the roof that attach directly to an existing drywall or plaster ceiling. Ceiling tiles offer an affordable way to add beauty. If ceiling tiles are acoustically absorbent and non-combustible can help maintain internal acoustic and prevent propagation of fire in case of fire.

SRW Ceiling Insulation

SRW Rockwool ceiling Insulation are available in Semi Rigid & Rigid forms with conformity to ASTM C 612, available with BFG / WOBFG facings for acoustical requirement on one side and Aluminum Foil facing on other side. SRW Rockwool ceiling Insulation have excellent acoustic properties along with high melting temperature which makes ceiling acoustical and fire proof and acts as passive fire protector.

Density

100 – 35Kg/m³

Thickness

100 - 25mm

Facing

Aluminum
BFG
WOBFG

NRC –Noise Reduction Coefficient

The **Noise Reduction Coefficient (NRC)** is a scalar representation of the amount of sound energy absorbed upon striking a particular surface.

NRC of 0 indicates = perfect reflection

NRC of 1 indicates = perfect absorption

Sound Transmission Class (STC) is an integer rating of how well a building partition attenuates airborne **sound**.

Thermal Properties



Density (Kg/m ³)	Thickness (mm)	NOISE REDUCTION COEFFICIENT						NRC
		Octave Frequencies (Hz)						
		125	250	500	1000	2000	4000	
40	75	0.21	0.92	1.24	1.15	1.07	1.1	1.1
50	50	0.28	0.72	1.01	1.02	0.98	0.98	0.95
	75	0.52	0.96	1.18	1.07	1.05	1.05	1
70	25	0.14	0.25	0.65	0.98	1.01	1.01	0.75
	30	0.1	0.4	0.87	0.97	0.9	0.9	0.8
	50	0.28	0.72	1.09	1.09	1.07	1.07	1
100	15	0.05	0.1	0.33	0.72	0.95	0.91	0.55
	25	0.1	0.4	0.8	0.95	0.94	0.9	0.8
	30	0.11	0.41	0.94	1.01	1.02	1.01	0.85
	50	0.33	0.86	1.1	1.09	1.05	0.98	1

Density (Kg/m ³)	Thermal Conductivity (W/m.K) Btu in / (h ft ² °F)		R-Value									U-Value							
			Thickness (mm)						Thickness (inch)			Thickness (mm)					Thickness (inch)		
			50	60	70	80	100	2	3	4	50	60	70	80	100	2	3	4	
35	0.038	0.26	1.32	1.58	1.84	2.11	2.63	8	11	15	0.76	0.63	0.54	0.48	0.38	0.13	0.09	0.07	
40	0.037	0.26	1.35	1.62	1.89	2.16	2.70	8	12	16	0.74	0.62	0.53	0.46	0.37	0.12	0.08	0.06	
50	0.036	0.25	1.39	1.67	1.94	2.22	2.78	8	12	16	0.72	0.60	0.51	0.45	0.36	0.12	0.08	0.06	
70	0.034	0.24	1.47	1.76	2.06	2.35	2.94	8	13	17	0.68	0.57	0.49	0.43	0.34	0.12	0.08	0.06	
100	0.033	0.23	1.52	1.82	2.12	2.42	3.03	9	13	17	0.66	0.55	0.47	0.41	0.33	0.11	0.08	0.06	
Units			m ² K/W						(h ft ² °F)/Btu			W/m ² K					Btu/(h ft ² °F)		

Insulated Red Bricks/Blocks

Bricks with insulation are referred as insulated Bricks or Blocks. Insulation bricks are mainly used for insulation in a building to reduce heat loss.

SRW Rockwool Panels

SRW Rockwool Panel manufactured in conformity to ASTM C 612 are customized to the size desired by Brick Manufacturers. We have a wide range of density and thickness suitable to their requirements.



Density

100 – 35K/m³

Thickness

100 – 50mm

Facing

None



NRC –Noise Reduction Coefficient

The **Noise Reduction Coefficient (NRC)** is a scalar representation of the amount of sound energy absorbed upon striking a particular surface.

NRC of 0 indicates = perfect reflection

NRC of 1 indicates = perfect absorption

Sound Transmission Class (STC) is an integer rating of how well a building partition attenuates airborne sound.

Density	Thickness	NOISE REDUCTION COEFFICIENT						NRC
		Octave Frequencies (Hz)						
(kg/m ³)	(mm)	125	250	500	1000	2000	4000	
40	75	0.21	0.92	1.24	1.15	1.07	1.1	1.1
50	50	0.28	0.72	1.01	1.02	0.98	0.98	0.95
	75	0.52	0.96	1.18	1.07	1.05	1.05	1
70	25	0.14	0.25	0.65	0.98	1.01	1.01	0.75
	30	0.1	0.4	0.87	0.97	0.9	0.9	0.8
	50	0.28	0.72	1.09	1.09	1.07	1.07	1
100	15	0.05	0.1	0.33	0.72	0.95	0.91	0.55
	25	0.1	0.4	0.8	0.95	0.94	0.9	0.8
	30	0.11	0.41	0.94	1.01	1.02	1.01	0.85
	50	0.33	0.86	1.1	1.09	1.05	0.98	1

Thermal Properties

Density	Thermal Conductivity		R-Value									U-Value							
			Thickness (mm)					Thickness (inch)				Thickness (mm)				Thickness (inch)			
(kg/m ³)	(W/m.K)	Btu in / (h ft ² °F)	50	60	70	80	100	2	3	4	50	60	70	80	100	2	3	4	
35	0.038	0.26	1.32	1.58	1.84	2.11	2.63	8	11	15	0.76	0.63	0.54	0.48	0.38	0.13	0.09	0.07	
40	0.037	0.26	1.35	1.62	1.89	2.16	2.70	8	12	16	0.74	0.62	0.53	0.46	0.37	0.12	0.08	0.06	
50	0.036	0.25	1.39	1.67	1.94	2.22	2.78	8	12	16	0.72	0.60	0.51	0.45	0.36	0.12	0.08	0.06	
70	0.034	0.24	1.47	1.76	2.06	2.35	2.94	8	13	17	0.68	0.57	0.49	0.43	0.34	0.12	0.08	0.06	
100	0.033	0.23	1.52	1.82	2.12	2.42	3.03	9	13	17	0.66	0.55	0.47	0.41	0.33	0.11	0.08	0.06	
Units			m ² K/W					(h ft ² °F)/Btu				W/m ² K				Btu/(h ft ² °F)			

Tank & Equipment Insulation

Tanks & Equipment are also integral part of any process industry. Equipment like turbine, furnace, reformers, boilers, ESP, Chimneys for any specific task, while tanks for the purpose of storing either raw material or finished products. Some times the storage of material demands to maintain specific temperature above or below ambient, and equipment also operate below or above ambient, may be very high temperature up to 650°C or more.

An efficient insulation system can help maintain the process temperature and reduces the heat gain or loss to its minimal level.

Energy efficiency, dependability and reliability under variable conditions of temperature, along with functionality of the process control, as well as mechanical durability are primary requirements from Insulation. Rockwool thermal insulation for piping plays a substantial role in satisfying these requirements.

SRW Rockwool Board and Lightly resin bonded Mattresses are most prominent & economical Insulation solution for Equipment and Tanks

SRW Rockwool Board / Mattresses

SRW Rockwool Board / Mattress are made from non-combustible, inorganic rock fibers and are Suitable for the insulation on equipment operating at temperature ranges between - 20 to + 0 75 C and are non-combustible to ASTM E 136, and as per BS EN 1182, has Euroclass fire classification "A1" & Class "O" fire classification in accordance with BS 476 Part- 7 & 6

SRW Rockwool Thermal Boards are manufactured in conformance to ASTM C 612, BS 3958 Part 5-, and other various international standards.

SRW Rockwool Lightly resin Bonded Wire mesh Blankets are manufactured in conformance to ASTM C 592 , BS 3958 Part 3-..

Thickness

SRW Rockwool Thermal Boards :- 200 - 50 mm
SRW Rockwool Mattresses :- 120 - 30mm

Density

SRW Thermal Boards :- 200 - 50kg / m³
SRW Mattress :- 150 - 80 Kg / m³

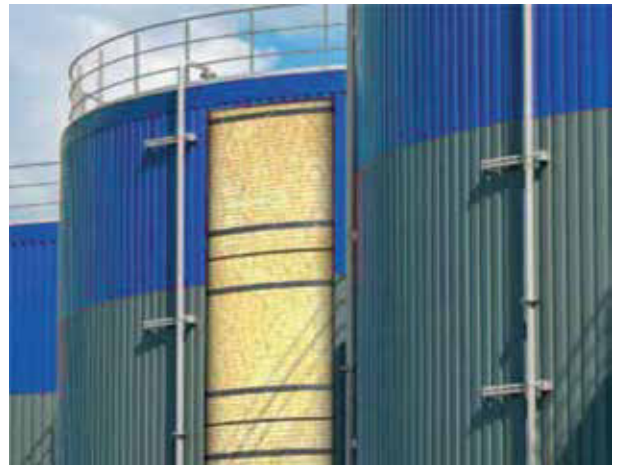

Facing

SRW Thermal Board :- None

SRW Mattress :- SS Wire Mesh / GI Wire Mesh

Pipe Insulation

Pipes network are integral part of any process industry like, refineries, fertilizers, cement plants, chemical process plants and power plants. Pipe networks transport types of fluid at different operating temperatures, though maintaining process temperature throughout the length of the pipes is challenging task. Some times the length of the pipe is in kilometers.

An efficient insulation system can help maintain the process temperature and reduces the heat gain or loss to its minimal level.

Energy efficiency, dependability and reliability under variable conditions of temperature, along with functionality of the process control, as well as mechanical durability are primary requirements from Pipe Insulation. Rockwool thermal insulation for piping plays a substantial role in satisfying these requirements.



SRW Rockwool Pipe Sections / Mattress

SRW Rockwool Pipe Section / Mattress are made from non-combustible, inorganic rock fibers and are suitable for the insulation on pipes operating at temperatures ranges between 20- to 750+ °C. Rockwool Pipe sections are non-combustible to ASTM E 136, and as per BS EN 1182, has Euroclass fire classification "A1" & Class "O" fire classification in accordance with BS 476 Part- 7 & 6

Pipe diameter up to 24"

SRW Rockwool Pipe Sections are manufactured in conformance to ASTM C 547, BS 3958 Part 4-, and other various international standards. SRW Pipe Sections are available up to 24" of pipe diameters. Pipe Sizes above shall be insulated with SRW Rockwool Mattresses.

Thickness

150 - 50mm

Density

150 - 100 Kg/m³

Facing

None / Aluminum Foil (FSK/FRK)

Product Range

Density (Kg/m ³)	Pipe Size inch	Pipe insulation ID (mm)	Thickness (mm)		Length (mm)
			Min	Max	
150 - 100	2/1	22	25	70	1200
	4/3	27	25	70	
	1	34	25	80	
	4/1 1	43	25	80	
	2/1 1	49	25	80	
	2	61	25	80	
	2/1 2	74	25	80	
	3	90	25	80	
	4	115	25	90	
	5	143	30	150	
	6	170	30	150	
	8	221	30	150	
	10	275	40	150	
	12	326	40	150	
	14	358	40	150	
	16	409	40	150	
18	460	40	150		
20	510	40	150		
22	561	40	150		
24	612	40	150		

* ID - Inner Diameter

Pipe diameter above 24"

SRW Rockwool Lightly resin Bonded Wire mesh Blankets are manufactured in conformance to ASTM C 592 , BS 3958 Part 3-..

Thickness

120 - 30mm

Density

150 - 80 Kg / m³

Facing

SS Wire Mesh

GI Wire Mesh

Thermal Calculations:

SRW factory provides thermal calculations using special software that complies with ASTM C680- to calculate the suitable insulation thickness, heat loss, insulation efficiency, condensation and control thickness based on process temp, ambient climate conditions, type and geometry of insulated surface.

Variable Insulation Thickness(mm)	Surface Temp (°C)	Heat Loss (W/m)	Efficiency (%)
Bare	496.30	9254.00	-
15.00	150.50	992.40	89.28
25.00	110.60	688.60	92.56
40.00	91.40	541.40	94.15
50.00	80.30	454.50	95.09
65.00	72.30	390.80	95.78
80.00	67.40	351.30	96.20
90.00	63.80	321.40	96.53
100.00	60.40	292.90	96.83
115.00	60.40	292.90	96.83
125.00	58.30	274.90	97.03
140.00	56.50	259.90	97.19
150.00	55.10	247.20	97.33
165.00	53.90	236.40	97.45
175.00	52.90	227.00	97.55
190.00	52.00	218.70	97.64
200.00	51.20	211.30	97.72
215.00	50.50	204.80	97.79
225.00	49.90	198.90	97.85
240.00	49.30	193.60	97.91
250.00	48.80	188.70	97.96

System Application = Pipe - Horizontal, Dimension Standard = ASTM C 585 Rigid
 Calculation Type = Heat Loss Per Hour Report, Process Temperature = 500
 Ambient Temperature = 40.0, Wind Speed = 3
 Nominal Pipe Size = 115, Bare Metal = Steel, Bare Surface Emittance = 0.8
 Insulation Layer 1 = 850F Mineral Fiber PIPE, Type I, C547-11
 Outer Jacket Material = Aluminium, oxidized, in service, Outer Surface Emittance = 0.1



Approvals

Saudi Civil defense, Saudi Aramco, Sabic, Ministry of Defense and Aviation, Ministry of Higher Education, Ministry of Interior, Ministry of Water, Institute of Public Administration, Maaden Aluminium, Manafia Gas Facilities, Petro Rabigh, Sadara, Saudi Arabia National Guard Housing (SANG), Saudi Railway Organization, Saudi Binladen Group (SBG), Zuhair Fayez Partnership, Saudi Oger Ltd, Dar Al-handasah, Capatial Market Authority - Saudi, Military Industrial General Establishment - Saudi, The General Organization for Social Insurance (GOSI), Saudi Border Guard, King Abdullah Financial District (KAFD)

Other Countries:

Dubai Central Laboratories
 Dubai Municipality
 Ministry of Health & Water, Kuwait
 Qatar Petroleum
 Qatar Civil Defense
 Bahrain Civil Defense
 Kuwait National Petroleum company
 ORPIC (JSRS)



Reference Projects

Industrial (Oil & Gas / Power plant)

Ras Al Khair Desalination and Power plant, Shuqaiq Power plant, Shaybah Desalination and Power plant, Marafiq Yanbu Desalination and Power plant, Power Plant 9 (PP9), Power Plant 10 (PP10), Power Plant 11 (PP11), Rabigh Power Plant, Jubail Oil Refinery, Jazan Refinery, Yanbu Refinery, Najran Refinery

Other countries:

Gas Qatar, Qatar Oil, Kuwait National Petroleum Company, Baghdad Oil Refinery

Cement Factories

Riyadh, Najran, Turaif, Jazan, Rabigh and Yanbu

Airports Projects

King Abdulaziz International Airport, Jeddah
 King Khalid International Airport, Riyadh
 Terminal 5, Riyadh
 Prince Mohammad Bin Abdulaziz International Airport, Madinah

Jizan Regional Airport
 Tabuk Regional Airport
 Al-Ahsa International Airport
 Abha Regional Airport
 Turaif Domestic Airport

Other Countries:

Dubai International Airport, Abu Dhabi International Airport
 Doha International Airport, Cairo Airport Terminal, Egypt
 Hurghada International Airport, Egypt, Sharm Al Sheikh Airport, Egypt, Lagos International Airport, Nigeria, Karachi International Airport, Pakistan



Office & Government

Jabal Omar Development Projects, King Abdullah Financial District (KAFFD), King Abdullah Petroleum Studies and Research Centre (KAPSARC), Information Technology and Communication Complex (ITCC), Aramco Maintenance, Al Harmain High Speed Rail, SANG Housing, King Abdulaziz Museum, Modon Dammam 2nd Industrial City, Modon Jeddah 3rd Industrial City, GOSI Olaya Tower, Ministry of Defense & Aviation, KAP Projects, SANG Villas

Other Countries:

Sheikh Jaber Al Ahmad International Stadium Project, Kuwait

Bahrain Financial Harbour

Central Bank, Egypt

Saudi Embassy, Egypt



Commercial & Residence

Riyadh Metro, Kingdom Tower, Faisalia Tower, Olayah Tower, Garnada Mall, Tamkeen Tower, Dream Tower, Rafal Tower, Blue Tower, Al Rashid Tower, Al Majdol Tower, Al Johara Tower, Hilton Hotel, Movenpick, Holiday Inn, Yanbu IPA Housing, Granada Business & Housing Park, Makkah Clock Tower, Expand Dahrhan Villas, Royal Commission Projects

Other Countries:

Burj Khalifa, Dubai

Dubai Maritime City

Bahrain International Circuit

World Trade Centre, Bahrain

City Centre, Bahrain

Bahrain Pearl Tower

Al Moayyed Tower, Bahrain

Qurum City Centre, Muscat

Al Fardan Residence, Doha

City Centre Expansion, Doha

Mina Al Ahmadi, Kuwait

Egyptian Media Production



Educational & Medical

Princess Nora University, King Saud University, King Abdulaziz University (KAU), Imam University, King Khalid University (KKU), Hail University, King Abdulaziz City for Science and Technology, Al Kharj University, Jazan University, Taif University, Islamic University, Taibah University, Om al Qura University, Al Qassim University, Baha University, Tabuk University, Najran University, King Faisal University, Kuwait National Library

SANG Hospitals, King Faizal Medical City, King Saud Medical City, Dallah Hospital, Dr Suleiman Al Habeeb Hospital, Kingdom Medical Center, Al Mouwasat Hospital Specialized Center City Hospital, Shemashi Hospital King Fahad Medical City, Abha Hospital, Taif Hospital Saudi German Hospitals

American Hospital, Kuwait

Amuma Hospital, Kuwait

International Hospital, Kuwait



STC calculation with diferent Systems

Example 1

System description:

Panel 1 Outer layer: 1 x 12.5 mm Gypsum platerboard
($m=10.0 \text{ kg}^2/\text{m}$, $f_c=2620 \text{ Hz}$, $\text{damping}=0.01$)

Cavity: Steel stud @ 600 mm, Infill Saudi Rockwool
Thickness 50 mm

Panel 2 Inner layer: 1 x 12.5 mm Gypsum plasterboard
($m=10.0 \text{ kg}/\text{m}^2$, $f_c=2620 \text{ Hz}$, $\text{damping}=0.01$)

Mass-air-mass resonant frequency = 120Hz

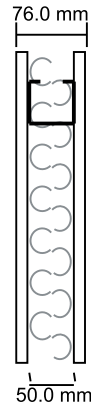

STC 40
OITC 28

frequency (Hz)	TL (dB)	TL (dB)
50	17	
63	17	17
80	17	
100	16	
125	16	17
160	23	
200	29	
250	34	32
315	39	
400	43	
500	47	46
630	50	
800	52	
1000	54	53
1250	54	
1600	55	
2000	53	49
2500	46	
3150	48	
4000	52	51
5000	55	

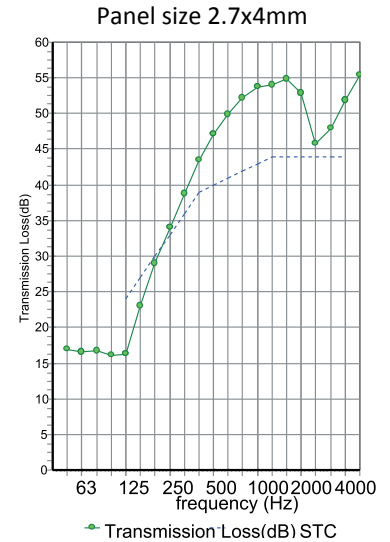

Example 2

System description:

Panel 1 Outer layer: 1 x 9.0 mm Cemboard ($m=11.7 \text{ kg}^2/\text{m}$,
 $f_c=3111 \text{ Hz}$, $\text{damping}=0.01$)

Cavity: Steel stud @ 600 mm, Infill Saudi Rockwool
Thickness 50 mm

Panel 2 Inner layer: 1 x 9.0 mm CemBoard ($m=11.7 \text{ kg}^2/\text{m}$,
 $f_c=3111 \text{ Hz}$, $\text{damping}=0.01$)

Mass-air-mass resonant frequency = 91Hz



STC 48
OITC 31

frequency (Hz)	TL (dB)	TL (dB)
50	17	
63	17	16
80	15	
100	19	
125	24	22
160	30	
200	35	
250	40	38
315	44	
400	48	
500	51	50
630	53	
800	55	
1000	56	56
1250	57	
1600	60	
2000	59	56
2500	54	
3150	49	
4000	53	52
5000	56	

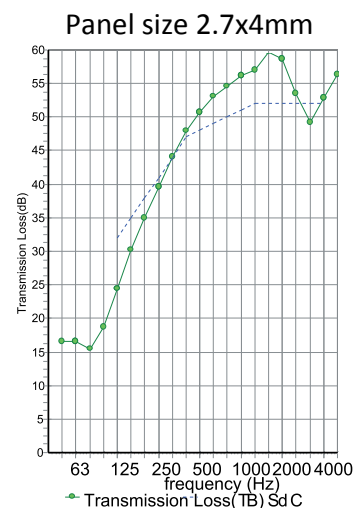

Example 3

System description:

Panel 1 Outer layer: 1 x 12.5 mm Gypsum plasterboard
($m=10.0 \text{ kg/m}^2$, $f_c=2620 \text{ Hz}$, $\text{damping}=0.01$)

Cavity: Steel stud @ 600 mm, Infill Saudi Rockwool

Thickness 50 mm

Panel 2 Inner layer: 1 x 12.5 mm Gypsum plasterboard

($m=10.0 \text{ kg/m}^2$, $f_c=2620 \text{ Hz}$, $\text{damping}=0.01$)

Mass-air-mass resonant frequency = 98Hz

frequency (Hz)	TL (dB)	TL (dB)
50	16	15
63	16	
80	15	
100	15	19
125	20	
160	27	
200	32	
250	37	35
315	41	
400	48	
500	51	
630	53	48
800	55	
1000	56	
1250	57	
1600	60	53
2000	59	
2500	54	
3150	49	
4000	53	19
5000	56	
5000	56	
4000	53	
3150	49	
2500	54	



STC 44
OITC 29

Panel size 2.7x4mm

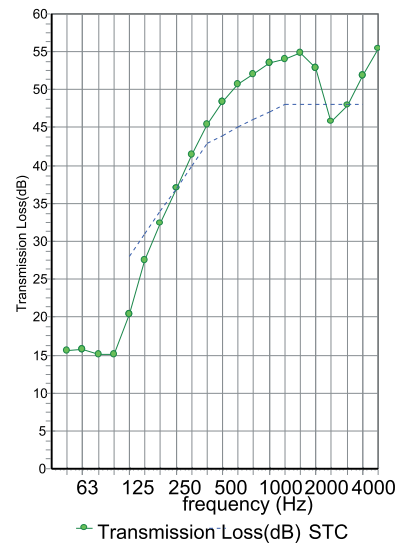

Example 4

System description:

Panel 1 Outer layer: 2 x 12.5 mm Gypsum plasterboard
($m=20.0 \text{ kg/m}^2$, $f_c=2620 \text{ Hz}$, $\text{damping}=0.01$)

Cavity: Steel stud @ 600 mm, Infill Saudi Rockwool

Thickness 75 mm

Panel 2 Inner layer: 2 x 12.5 mm Gypsum plasterboard

($m=20.0 \text{ kg/m}^2$, $f_c=2620 \text{ Hz}$, $\text{damping}=0.01$)

Mass-air-mass resonant frequency = 60Hz

frequency (Hz)	TL (dB)	TL (dB)
50	18	20
63	18	
80	26	
100	32	35
125	36	
160	41	
200	45	
250	49	48
315	52	
400	54	
500	56	
630	57	55
800	59	
1000	60	
1250	60	
1600	61	60
2000	59	
2500	53	
3150	55	
4000	58	56
5000	62	
5000	62	
4000	58	
3150	55	
2500	53	

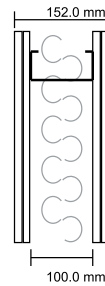

STC 56
OITC 43

Panel size 2.7x4mm

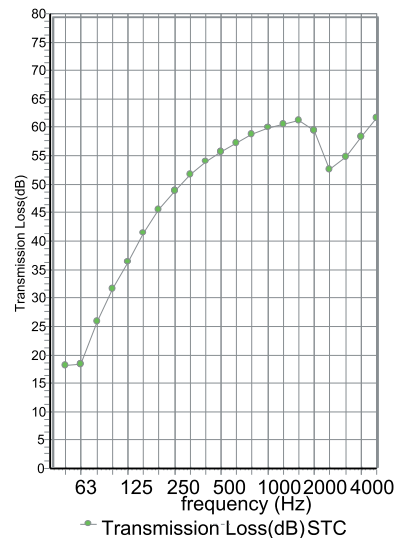

Example 5

System description:

Panel 1 Outer layer: 1 x 200 mm until conc blocks (m=177.2 kg/m², fc=248 Hz, damping=0.01)

Cavity: Steel stud @ 600 mm, Infill Saudi Rockwool

Thickness 50 mm

Panel 2 Inner layer: 1 x 12.5 mm Gypsum plasterboard (m=10.0 kg/m², fc=2620 Hz, damping=0.01)

Mass-air-mass resonant frequency = 71Hz

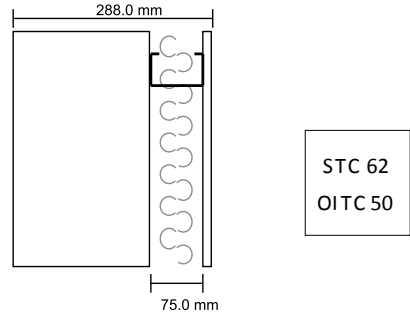

frequency (Hz)	TL (dB)	TL (dB)
50	33	33
63	31	
80	35	
100	40	43
125	43	
160	47	
200	48	49
250	48	
315	53	
400	56	59
500	59	
630	63	
800	65	66
1000	66	
1250	68	
1600	69	70
2000	71	
2500	70	
3150	72	74
4000	75	
5000	77	

Panel size 2.7x4mm

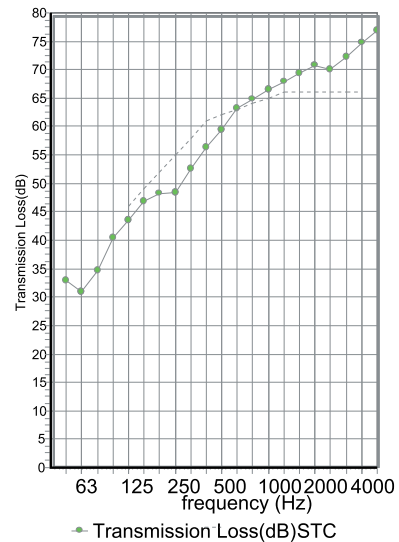

Example 6

System description:

Panel 1 Outer layer: 1 x 1.1 mm steel (m=8.6 kg/m², fc=11364 Hz, damping=0.01)

Panel 1 Inner layer: 2 x 12.0 mm Fibre Cement (m=31.0 kg/m², fc=3023 Hz, damping=0.01)

Cavity: Suspended light steel grid @ 450 mm, Infill Rockwool (60kg/m³) Thickness 120 mm

Panel 2 Inner layer: 1 x 10.0 mm CemBoard (m=13.0 kg/m², fc=2800 Hz, damping=0.01)

Panel 2 Outer layer: 1 x 0.9 mm Aluminium (m=2.6 kg/m², fc=13295 Hz, damping=0.01)

Mass-air-mass resonant frequency = 46Hz

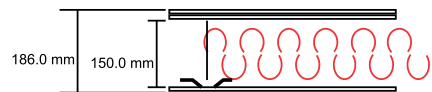

frequency (Hz)	TL (dB)	TL (dB)
50	22	25
63	28	
80	34	
100	39	42
125	43	
160	47	
200	50	52
250	53	
315	55	
400	57	58
500	58	
630	60	
800	62	63
1000	63	
1250	64	
1600	65	65
2000	66	
2500	65	
3150	58	61
4000	61	
5000	64	

RW 61
C 2-
Ctr 6-

Panel size 2.7x4mm

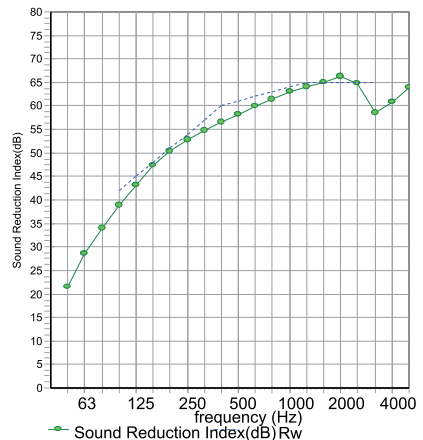

Thermo-Physical Properties of Building Materials

* Thermal conductivity (k-value)

The k-value of a material is defined as the quantity of heat transmitted under steady-state conditions through unit area of the material of unit thickness in unit time when unit temperature difference exists between its opposite surfaces. It is expressed in W/m.K.

The thermal resistance is a heat property and measurement of a temperature difference by which an object or material resist a flow (m^2K/W).

$R=X/K$, X- Material thickness (mm) & K- Thermal conductivity (w/mK)

Total Thermal Resistance: (RT)

The thermal resistance of a material or construction is the reciprocal of its thermal conductance. It refers to the thermal resistance of any section or assembly of building components and is particularly useful in computing the overall transfer of heat across the building section. It is expressed as $m^2.k/W$ and is given by:

$$RT = R1 + R2 + R3 \dots RN$$

Construction Materials Thermal Conductivity & Thermal Resistance Table

Table Thermal Conductivity Values (k-Values) of Basic Materials S/No	Material	Density (kg/m ³)	k-value (W/m. K)
1	Asphalt, roofing	2240	1.226
2	Bitumen	-	1.298
3	Brick	1760	0.807
	(a) dry (covered by plaster or tiles outside)		
	(b) common brickwall (brickwall directly exposed to weather outside).	-	1.154
4	Concrete	2400	1.442
		64	0.144
5	Concrete, lightweight	960	0.303
		1120	0.346
		1280	0.476
6	Cork board	144	0.042
7	Fibre board	264	0.052
8	Fibre glass (See Glass Wool and Mineral Wool)		
9	Glass, sheet	2512	1.053
10	Glass wool, mat or guilt (dry)	32	0.035
11	Gypsum plaster board	880	0.170
12	Hard board:		
	(a) Standard	1024	0.216
	(b) medium	640	0.123
13	Metals:		
	a) Aluminium alloy,) typical	2672	211
	(b) Copper, com - mercial	8784	385
	(c) Steel	7840	47.6
14	Mineral wool, felt	104- 32	0.032- 0.035

Table Thermal Conductivity Values (k-Values) of Basic Materials S/No	Material	Density (kg/m ³)	k-value (W/m K)
15	Plaster:		
	(a) gypsum	1216	0.370
	(b) perlite	616	0.115
	(c) sand / cement	1568	0.533
	(d) vermiculite	960- 640	0.303- 0.202
16	Polystyrene, expanded	16	0.035
17	Polyurethane, foam	24	0.024
18	PVC flooring	1360	0.713
19	Soil, loosely packed	1200	0.375
20	Stone, tile:		
	(a) sand stone	2000	1.298
	(b) granite	2640	2.927
	(c) marble / terrazzo / ceramic / mosaic	2640	1.298
21	Tile, roof	1890	0.836
22	Timber:		
	a) across grain) softwood	608	0.125
	b) hardwood)	702	0.138
	c) plywood)	528	0.138
23	Vermiculite, loose granules	112-80	0.065
24	Wood chipboard	800	0.144
25	Woodwool slab	400	0.086
		480	0.101

Resistance from Air Films and Air Spaces

Air films are layers of air that are assumed to be static on each side of a building envelope, and air spaces are volumes of air within building constructions they are both interesting thermal components they have potentially useful thermal properties. They can contribute substantially to the insulating capabilities of construction assemblies -

Type of Surface	Thermal Resistance (m ² K/W)
A. Surface Film Resistances for Walls	
1. Inside Surface (R _i)	
(a) High emissivity	0.120
(b) Low emissivity	0.299
2. Outside surface (R _o) - High emissivity	0.044
B. Surface Film Resistances for Roofs	
1. Inside surface (R _i)	
(a) High Emissivity	
(i) Flat roof	0.162
(ii) Sloped roof 22½°	0.148
(iii) Sloped roof °45	0.133
(b) Low Emissivity	
(i) Flat roof	0.801
(ii) Sloped roof 22½°	0.595
(iii) Sloped roof °45	0.391
2. Outside surface (R _o) - High emissivity	0.055
Flat or sloped	

Type of Air Space	Thermal Resistance (m ² K/W)		
	5mm	20mm	100mm
A. Air Space Resistances (R_a) for walls Vertical air space (Heat flows horizontally)			
(a) High emissivity	0.110	0.148	0.160
(b) Low emissivity	0.250	0.578	0.606
B. Air Space Resistances (R_a) for Roofs Horizontal or sloping air space (Heat flows downwards)			
(a) High emissivity			
(i) horizontal air space	0.110	0.148	0.174
(ii) sloped air space 22½°	0.110	0.148	0.165
(iii) sloped air space °45	0.110	0.148	0.158
(b) Low emissivity			
(i) horizontal air space	0.250	0.572	0.768
(ii) sloped air space 22½°	0.250	0.571	1.423
(iii) sloped air space °45	0.250	0.570	1.095
C. Attic space resistances (R_{atic})			
(a) High emissivity	0.458		
(b) Low emissivity	1.356		

Thermal Transmittance (U-value):

The thermal transmittance or U-value of a construction is defined as the quantity of heat that flows through a unit area of a building section under steady-state conditions in unit time per unit temperature difference of the air on either side of the section. It is expressed in W/m².k and is given by:

$$\text{Thermal Transmittance (U-Value)} = 1/RT$$

Example 1: Thermal Resistance & Thermal Transmittance Calculation for a Wall

WALL Elements	Thermal Resistance
1 External Air Film	R0.044 1
2 Building stone 7cm	R0.05 2
3 Concrete 20cm	R0.14 3
4 Rockwool panels 5cm	R1.47 4
5 Hollow Cement Bricks 10cm	R0.087 5
6 External Plaster 2cm	R0.037 6
7 Internal Air Film	R0.123 7

Total Thermal Resistance:

$$RT = R1 + R2 + R3 + R4 + R5 + R6 + R7$$

$$RT = 0.123 + 0.037 + 0.087 + 1.47 + 0.14 + 0.05 + 0.044$$

$$RT = 1.951 \text{ m}^2 \cdot \text{k/W}$$

$$U = 1/RT = 0.512 \text{ W/m}^2 \cdot \text{k}$$

Example 2: Thermal Resistance & Thermal Transmittance Calculation for a Roof

Roof Elements	Thermal Resistance
1 External Air Film	R0.055 1
2 Screed 5cm	R0.0285 2
3A Reinforced Concrete 25cm	R3A 0.173
3B Reinforced Concrete 7cm	R3B 0.048
4 Rips 18 cm	R0.189 4
5 Rockwool Panels 5cm	R1.47 5
6 False ceiling 1.2cm	R0.90 6
8 Internal Air Film	R0.162 8

Total Thermal Resistance:

$$RT = R1 + R2 + R3A + R3B + R4 + R5 + R6 + R8$$

$$RT = 1.47 + 0.189 + 0.048 + 0.173 + 0.0285 + 0.055 + 0.162 + 0.90$$

$$RT = 3.021 \text{ m}^2 \cdot \text{k/W}$$

$$U = 1/RT = 0.331 \text{ W/m}^2 \cdot \text{k}$$

A series of horizontal dotted lines for writing notes.



Head office :

Riyadh : 11383 P.O.Box 145 Kingdom of Saudi Arabia
Tel: + 966 11 2650034 Fax: + 966 11 2650089

Branch office:

Al Khobar : 31952 P.O.Box 49455 Kingdom of Saudi Arabia
Tel: + 966 13 8875119 Fax: + 966 13 8820100

Jeddah : 21424 P.O.Box 14324 Kingdom of Saudi Arabia
Tel: + 966 12 6673781 Fax: + 966 12 6695869

Overseas office:

UAE : PO Box 44493, Dubai
Tel. Office : + 971-4-2959739 / + 971-4-2940424

Qatar : Zamil Group LLC, Post Box No. 22162,
Gate No 1, Floor No. 2, Door No. 6, Town Center, Doha
Tel: + 974 4486 9312 Fax: + 974 4486 9319

www.saudirockwool.com
Email: sales@saudirockwool.com

